

**JD Metals**

**LINKING QUALITY & SERVICE**

# **Tuff-Rib Installation Guide**

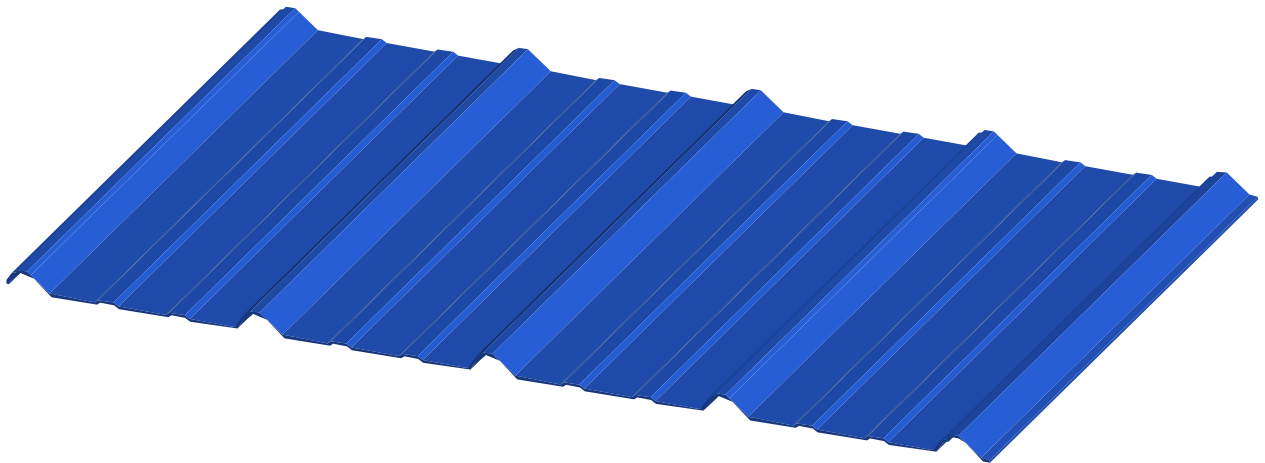



# Table of Contents

<i>Description</i>	<i>Page</i>
JD Metals Requirements	1
Fasteners	2
Trim	3-5
Vented Ridge & Hip/Ridge Details	6
Rake Details	7
High Side Eave Details	8
Eave Details	9
Endwall & Sidewall Details	10
Transition & Gambrel Details	11
Valley & Snow Guard Details	12
Overhead & Typ. Opening Details	13
Base & Double Angle Details	14
Eave / Soffit / Fascia Details	15
Inside & Outside Corner Details	16
Chimney Detail	17
Care & Cleaning Instructions	18
Types of Cleaners	19
Dirt Retention, Chalk and Mildew	20
Rust Removal	21

# TUFF-RIB

## GENERAL NOTES

- A. Contact JD Metals for a list of approved fasteners.
- B. Before releasing materials for fabrication, it is recommended that panel lengths, quantities, profiles and dimensions of flashings or flat sheet quantities be verified through field measurements. JD Metals shall not be liable for any back charges for errors and/or omissions after approved orders are released for fabrication by the customer.
- C. Before beginning installation, carefully inspect the substrate /roof deck. Do not begin installation of the metal roof system if the substrate (trusses, joists, subgirts/furring strips, plywood deck, steel deck, insulation) is in an unsatisfactory condition, as such conditions can cause oil canning of panels. It is the responsibility of the installer to correct or demand remedy of unsatisfactory substrate conditions prior to installation of metal roof system.
- D. JD Metals recommends that if the roof deck is unacceptable the roofing contractor has the authority to reject this deck prior to installation of metal roof system. Once installation of the metal roof system has begun, the contractor forfeits the ability to reject the metal roofing system based on substandard deck. Oil canning is not a cause for rejection.
- E. The industry has accepted a certain amount of waviness or oil canning evident in the flat area of the rib/seam panels. This is more evident on longer length panels, particularly when viewed from different angles. This shall not be construed as a product defect and shall not be cause for product refusal.
- F. Panel crates must be lifted at bundle block locations. Do not lift material with only ropes or wires. Do not lift panels greater than 25'-0" long without a spreader bar. Do not lift panels from ends while flat. Do not lift panels on edge.
- G. Installation of metal panels must be started so that the sheets are held true, plumb, and straight. Note that all panel width dimensions are nominal. During panel installation, it is recommended that periodic checks/measurements be taken to ensure that the panels are not gaining or losing width.
- H. During the panel installation, do not use undue pressure to interlock panel. Do not force or push panels together. To reduce wavy, oil canning panel appearance and to increase the aesthetics of an installation, a camber or outward bowing may be forced into flat area of the panel as the fastener and/or clip is installed. However. Care must be taken to prevent "fish mouthing" at panel ends.
- I. JD Metals is not responsible for the adequacy of attachment of its framing members to other surface conditions. JD Metals shall be held harmless for fasteners used for such attachments.
- J. Ensure that acid residue from cleanup of stucco in the adjacent panel areas is not washed down directly over the panels. This could mar the finish/coating.
- K. Avoid damage or scratching of the exterior surface caused by walking, use of improper tools, improper storage, etc.
- L. Flashings must lap a minimum of 6". Treat flashing endlaps similar to a panel detail utilizing two rows of sealant tape with stitch screws 4" o.c. maximum. Lap flashings shingle style to allow for water flow.
- M. Always use tape sealant or butyl between roof components where there will be movement. These types of sealants do not cure. Therefore, they permit movement while still providing a seal. Polyurethane sealants are recommended when voids must be filled and there is no movement.
- N. If the material is not to be used immediately, it should be stored in a dry place where exposure to moisture is minimal. Moisture (from rain, snow, condensation, etc.) trapped between pieces of material may cause water stains or white rust, which detract from its appearance. To avoid staining or white rust, store the material in a well-ventilated dry area. Break the steel strapping bands used for shipment and store the stacks of material with a canvas or waterproof paper cover. Do not use plastic, which can cause sweating or condensation. Keep the material off the ground in an inclined position with an insulator such as wood. It is the responsibility of the contractor to insure that all materials are properly stored at the jobsite.

# TUFF-RIB

## FASTENERS

### Abuse of Fasteners

The abuse of fasteners by installers, causing damage to the paint and sub coatings, results in allowing rust to form where finish had been compromised.

The most common mistakes made during installation:

1. Using worn out drivers bits causing bit to spin/slip on head of the Fastener.
2. Not fully engaging the driver bit into the external/internal drive system of the fastener
3. Not keeping the Driver vertical to the Fastener during installation.
4. The use of impact drivers.
5. Striking head of Fastener with hammer or other metal object.



# JD Metals

LINKING QUALITY & SERVICE

## TUFF-RIB

### RIDGE CAP (10'-6")

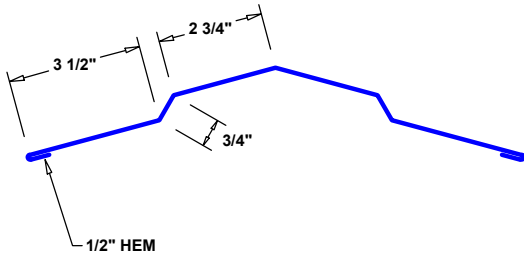

### "W" VALLEY (10')

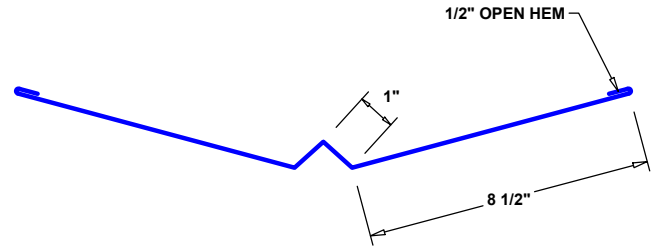

### NARROW OUTSIDE CORNER (10' - 20')

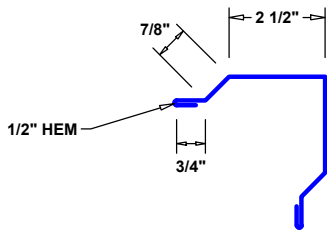

### WIDE OUTSIDE CORNER (10' - 20')

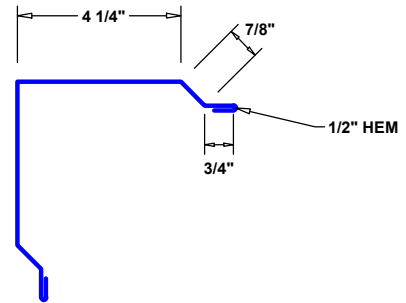

### RESIDENTIAL RAKE (10'-20')

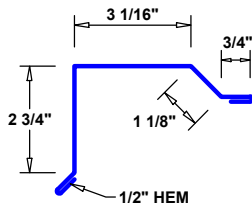

### STEP RAKE (10'-20')

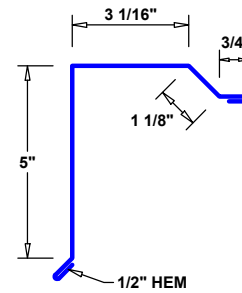

### STANDARD RAKE (10'-20')

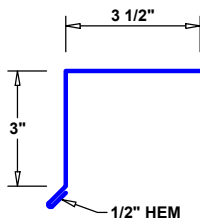

### HIGH SIDE EAVE (10')

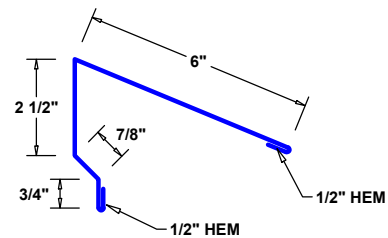

### DRIP EDGE (10')

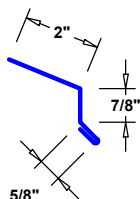

### 2" X 4" DRIP EDGE (10'-6")

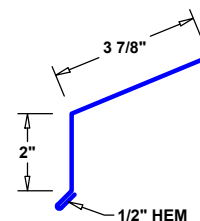

# TUFF-RIB

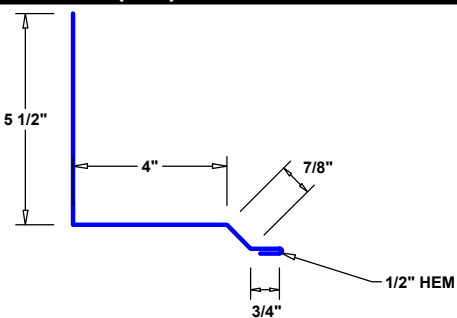
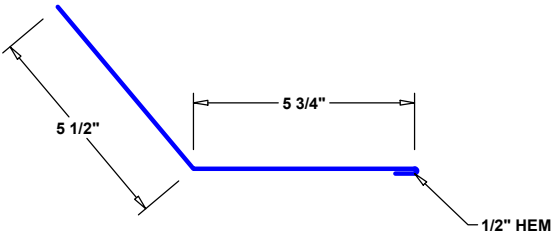
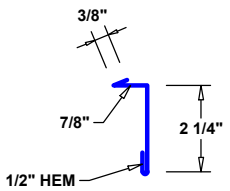
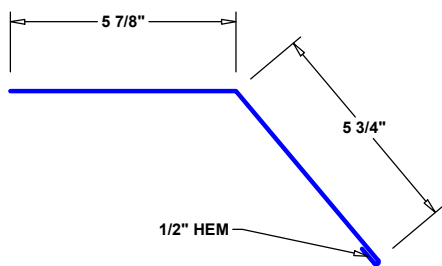
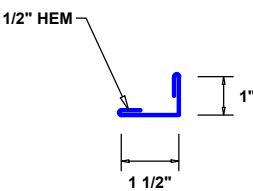
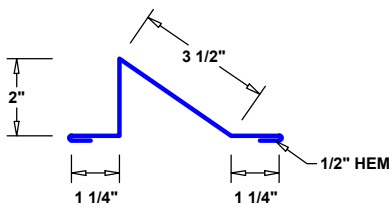
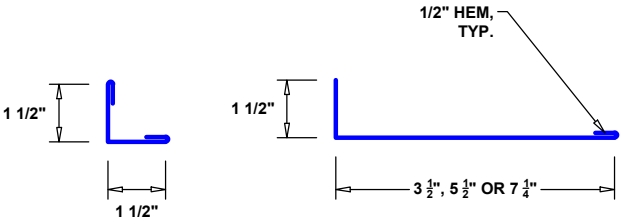
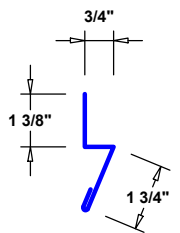
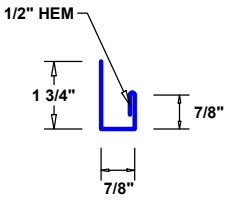
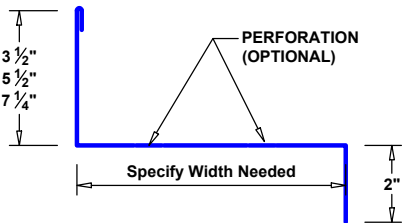
<p><b>SIDEWALL (10')</b></p> 	<p><b>ENDWALL (10')</b></p> 
<p><b>REGLET (10')</b></p> 	<p><b>GAMBREL FLASHING (10')</b></p> 
<p><b>SNOW GUARD (10')</b></p> 	<p><b>CAROLINA SNOW GUARD (10')</b></p> 
<p><b>FASCIA (10')</b></p> 	<p><b>RAT GUARD (10')</b></p> 
<p><b>J-CHANNEL (10')</b></p> 	<p><b>SOFFIT FASCIA COMBO (10'-6")</b></p> 

# TUFF-RIB

**OVERHEAD DOOR TRIM (10'-20')**

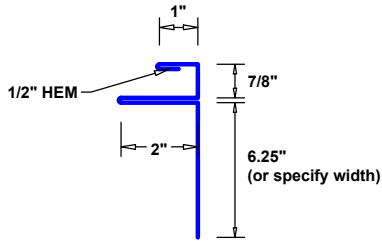

**INSIDE CORNER (10'-20')**

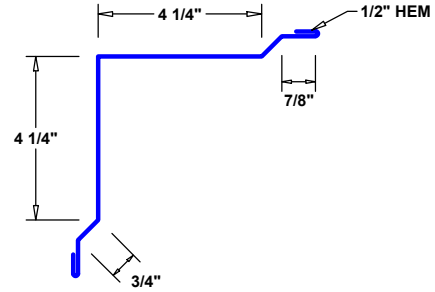

**DOUBLE ANGLE (10')**

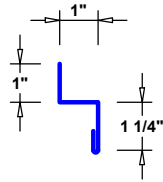

**ROUND DOOR TRACK COVER (10')**

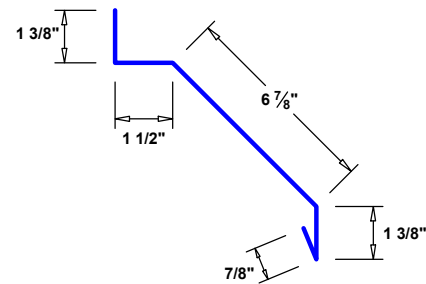

**DOUBLE ROUND DOOR TRACK (10')**

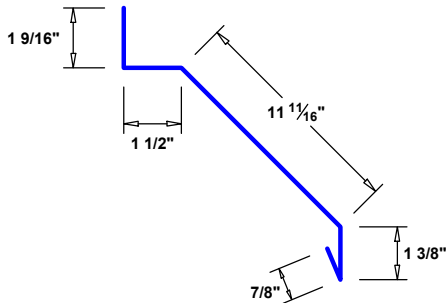

**SQUARE DOOR TRACK COVER (10')**

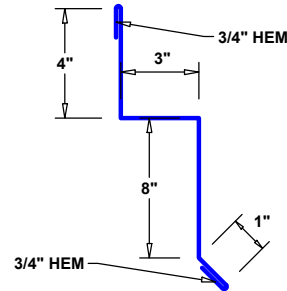

**D-5 DOOR TRIM (10')**

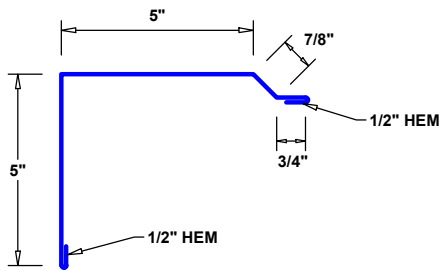

**D-10 DOOR TRIM (10')**

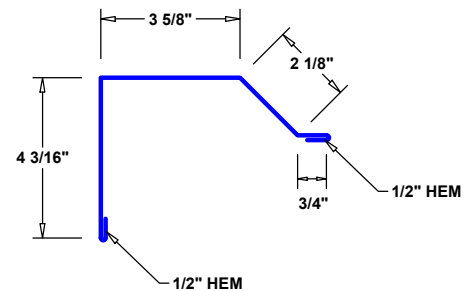



**JD Metals**

LINKING QUALITY & SERVICE

# TUFF-RIB

## VENTED RIDGE DETAIL

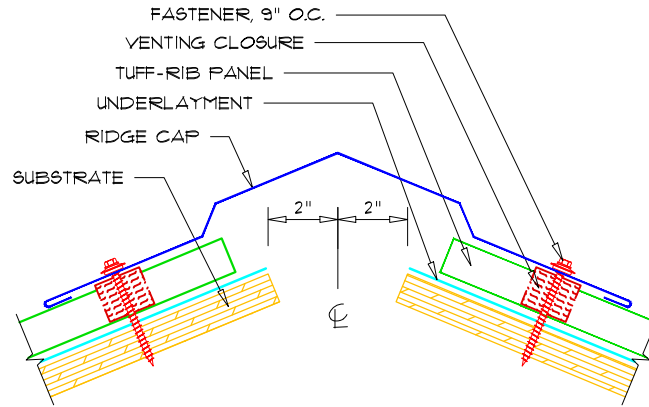

## HIP / RIDGE DETAIL

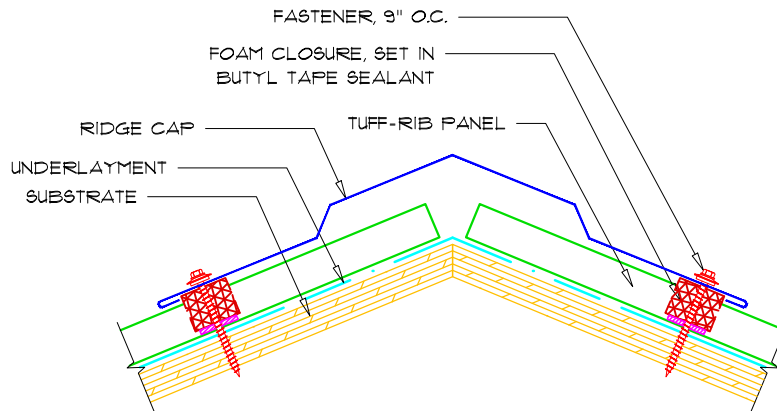



# TUFF-RIB

## RAKE DETAIL

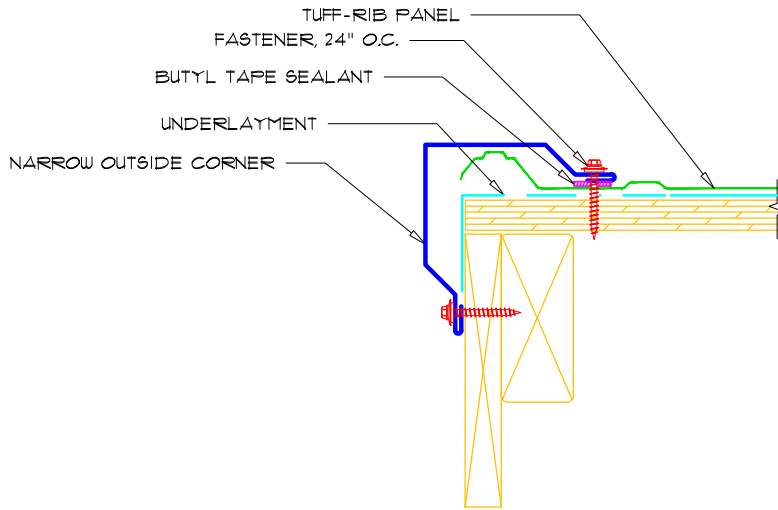

## ALT. RAKE DETAIL

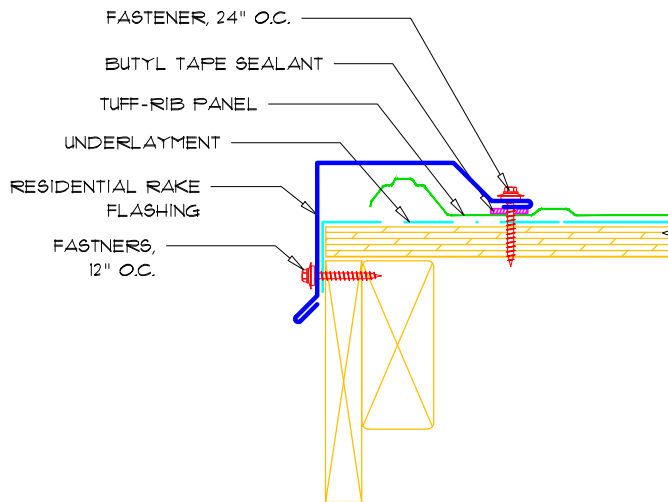



# TUFF-RIB

## HIGH SIDE EAVE DETAIL

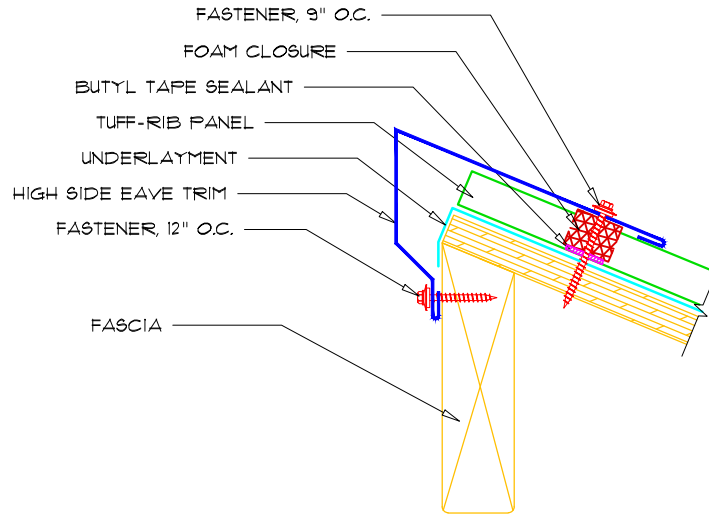

## ALT. HIGH SIDE EAVE DETAIL

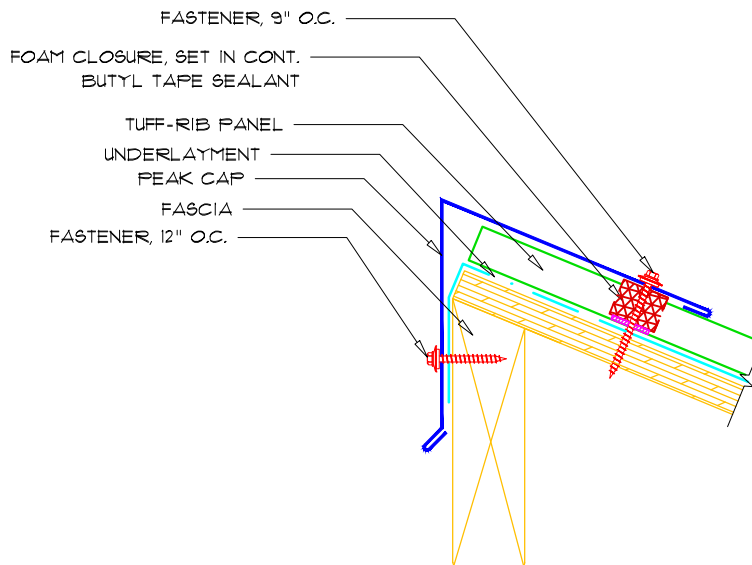



# TUFF-RIB

## EAVE DETAIL

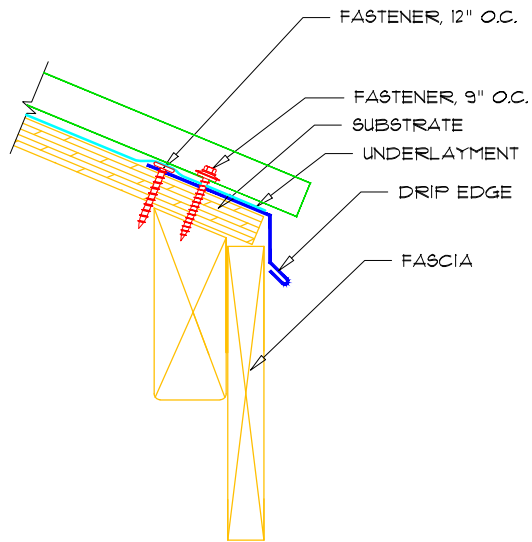

## ALT. EAVE DETAIL

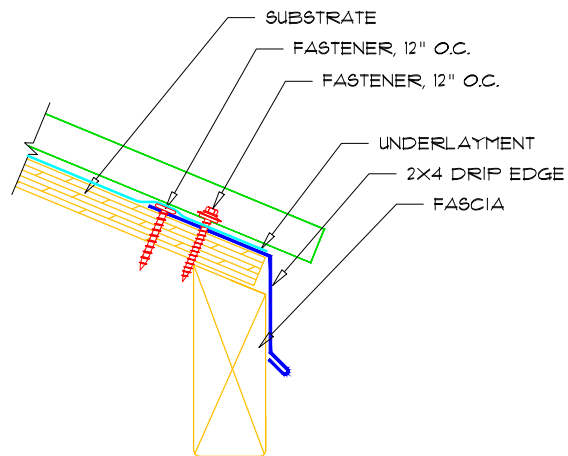



# TUFF-RIB

## ENDWALL DETAIL

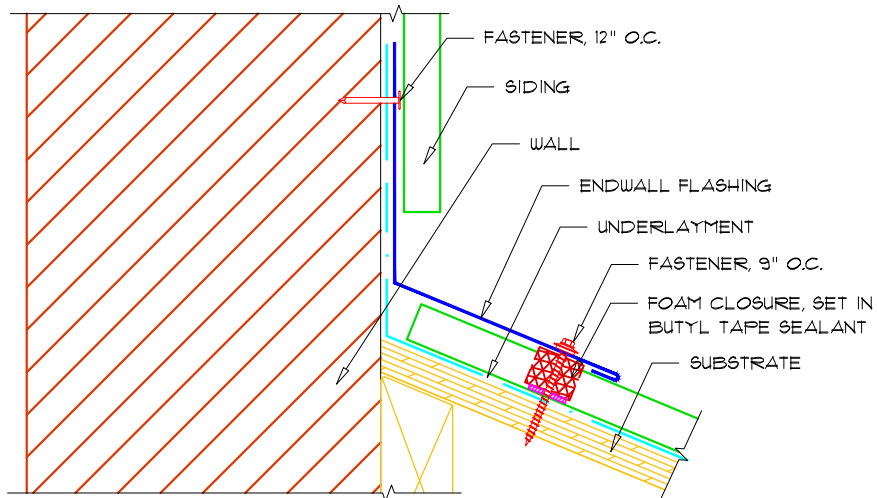

## SIDEWALL DETAIL

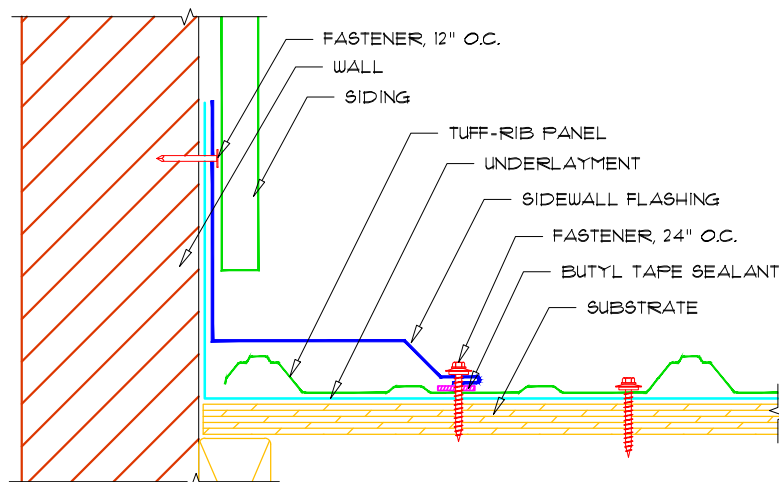



# TUFF-RIB

## TRANSITION DETAIL

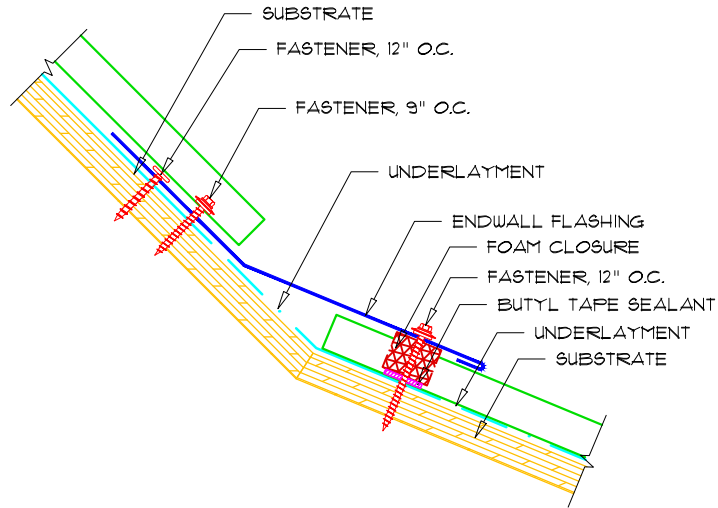

## GAMBREL DETAIL

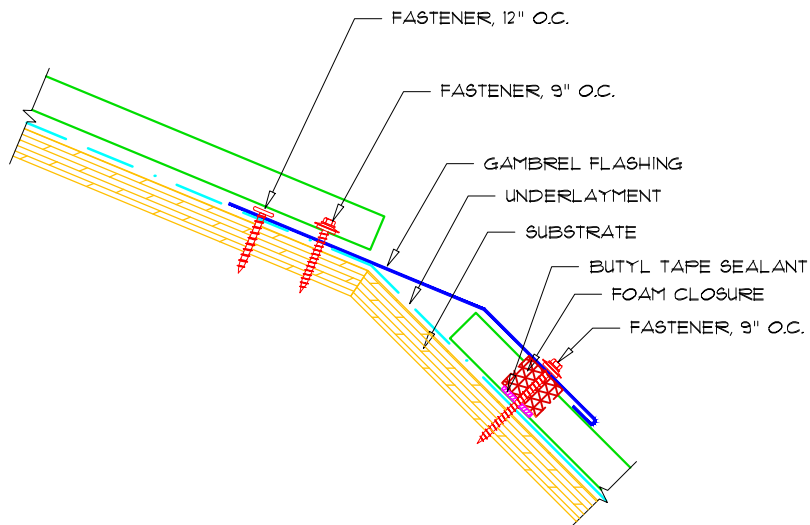



## TUFF-RIB

### VALLEY DETAIL

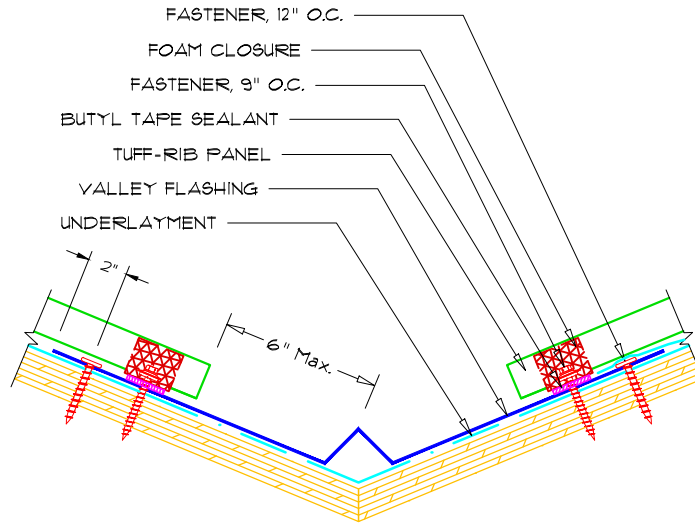

### SNOW GUARD DETAIL

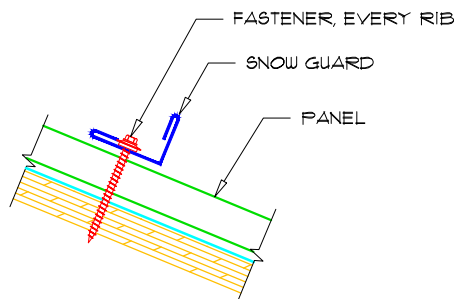

2" X 1" ANGLE SNOW GUARD

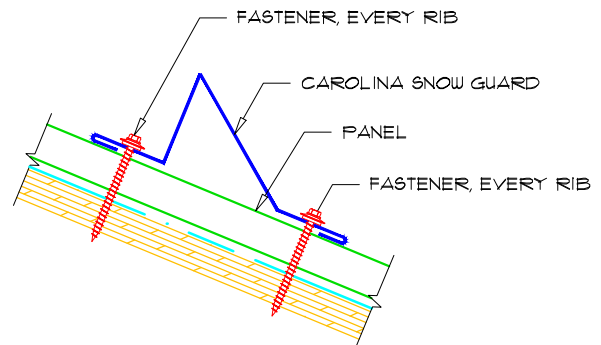

ALT. CAROLINA SNOW GUARD



# TUFF-RIB

## OVERHEAD DOOR DETAIL

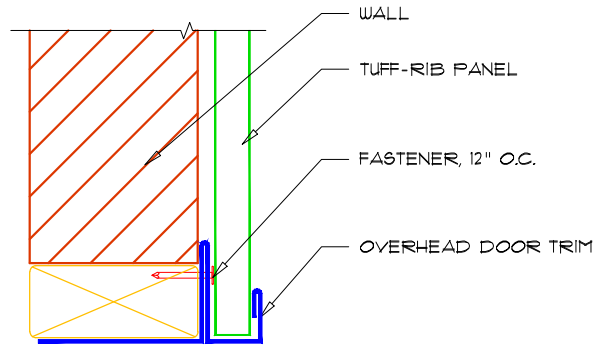

## TYP. OPENING DETAIL

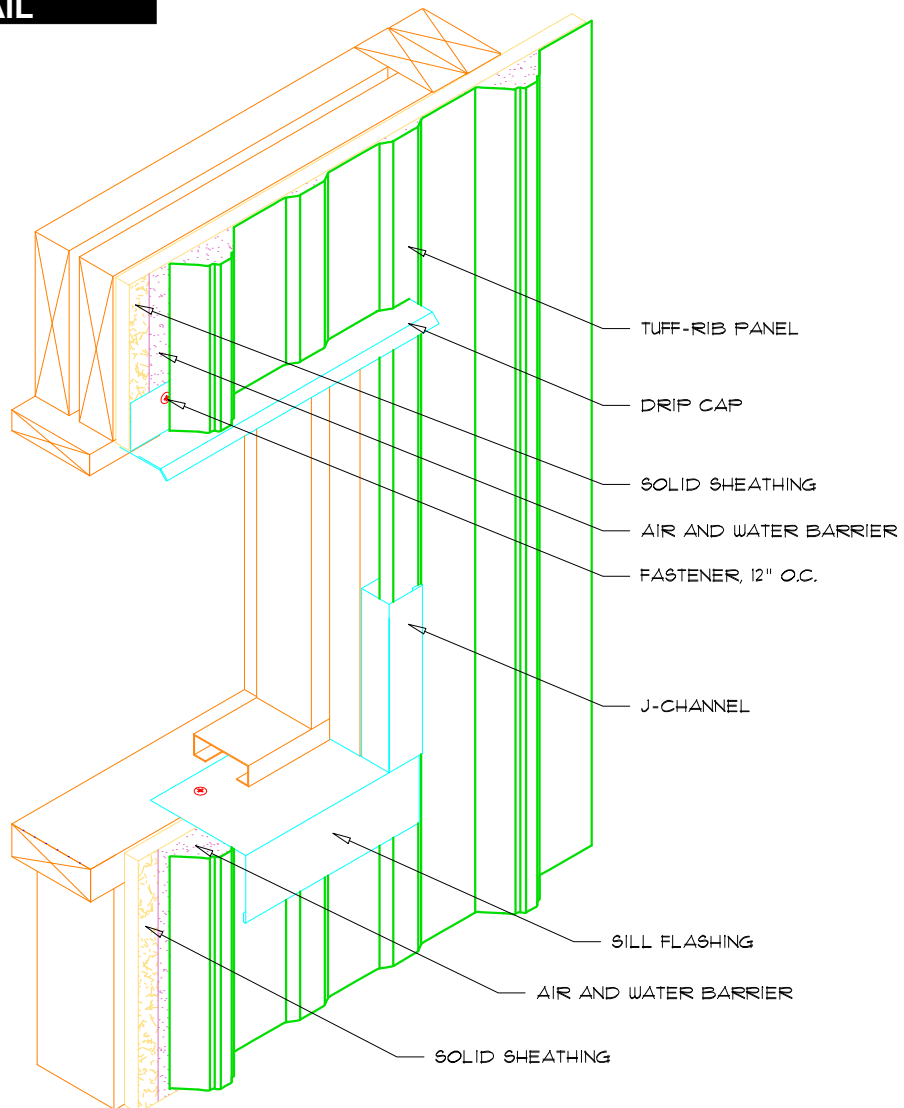



**JD Metals**

LINKING QUALITY & SERVICE

# TUFF-RIB

## BASE DETAIL

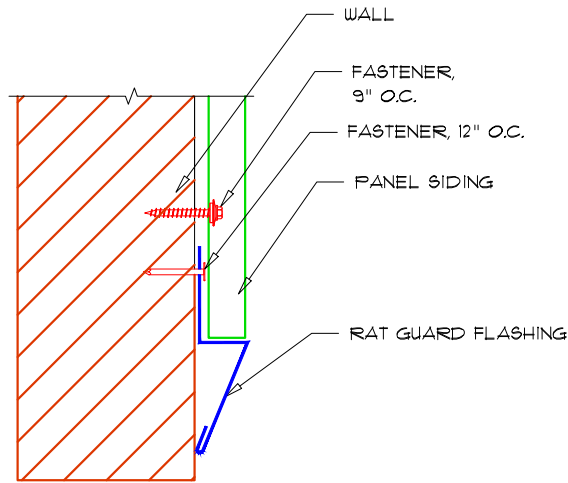

## DOUBLE ANGLE DETAIL

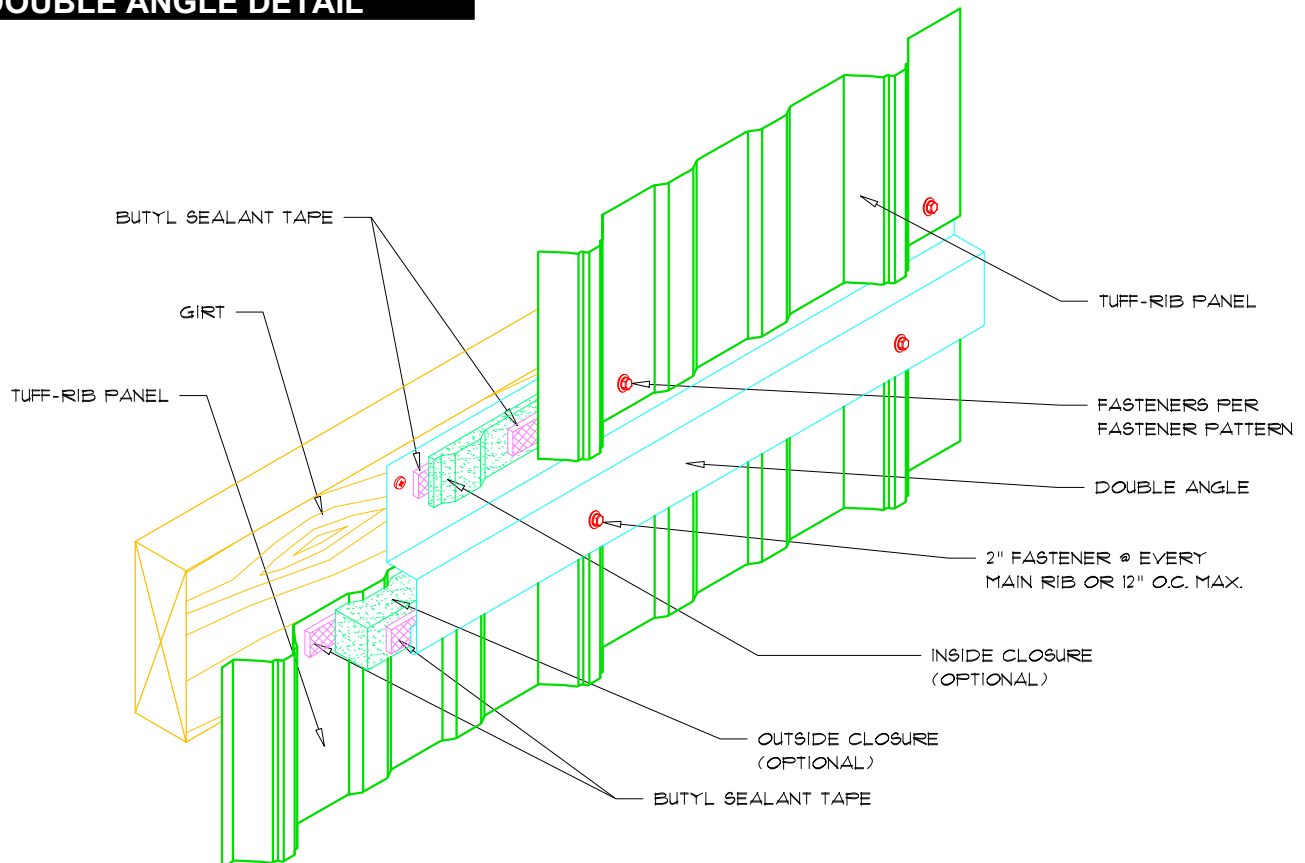





# TUFF-RIB

## EAVE / SOFFIT DETAIL

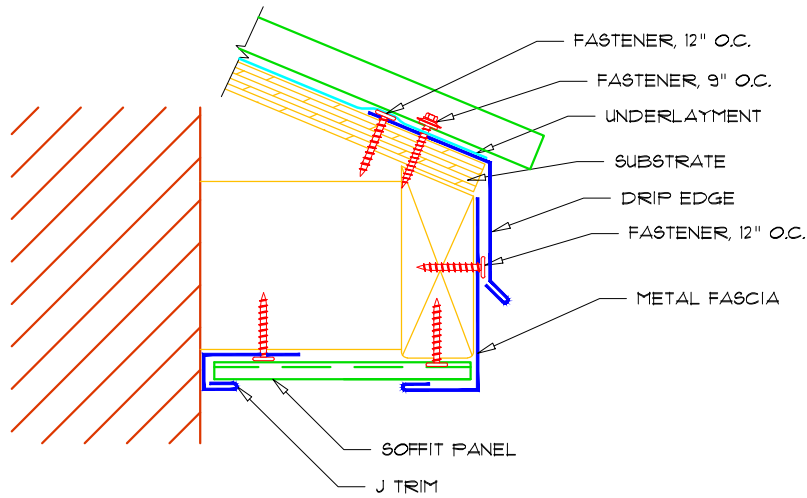

## SOFFIT FASCIA COMBO DETAIL

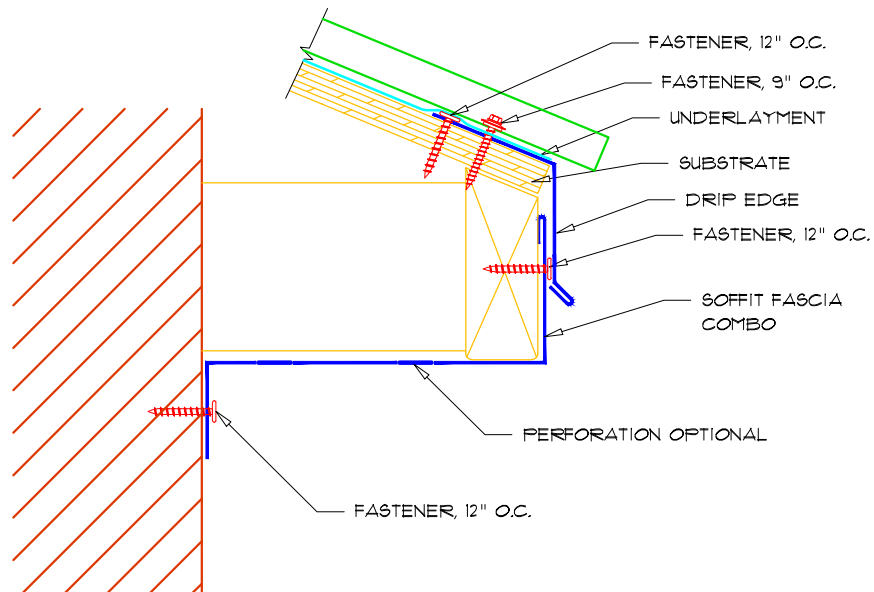



# TUFF-RIB

## INSIDE CORNER DETAIL

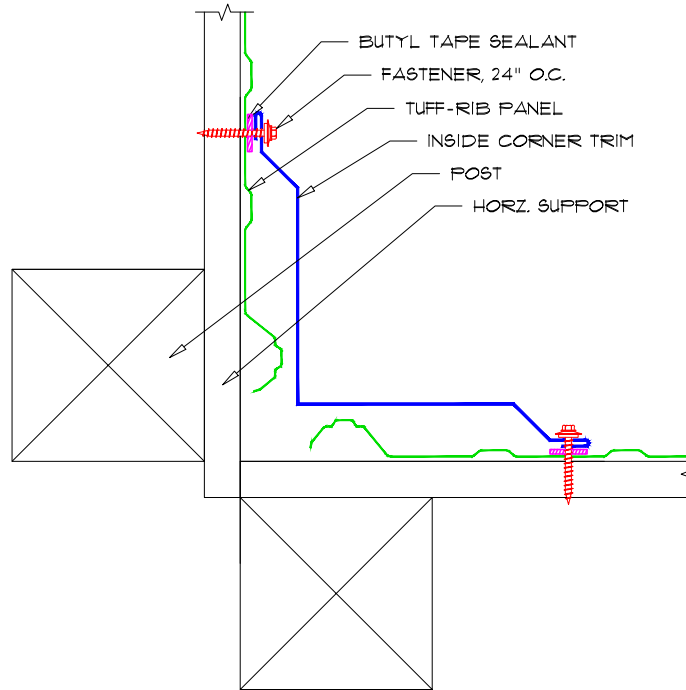

## OUTSIDE CORNER DETAIL

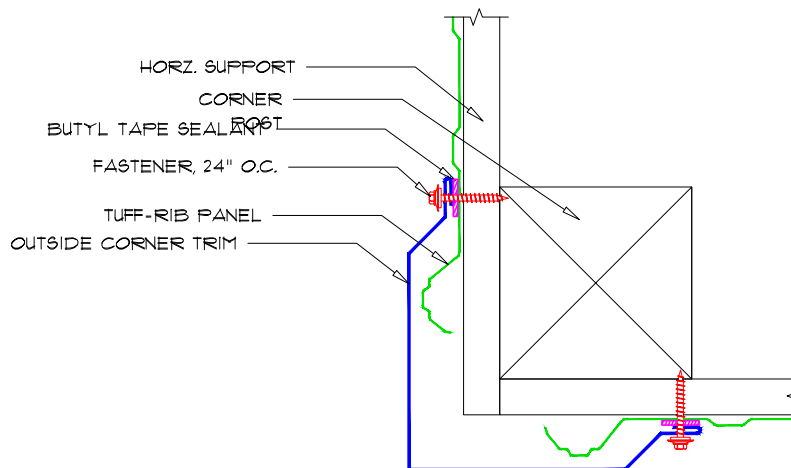



# TUFF-RIB

## CHIMNEY DETAIL

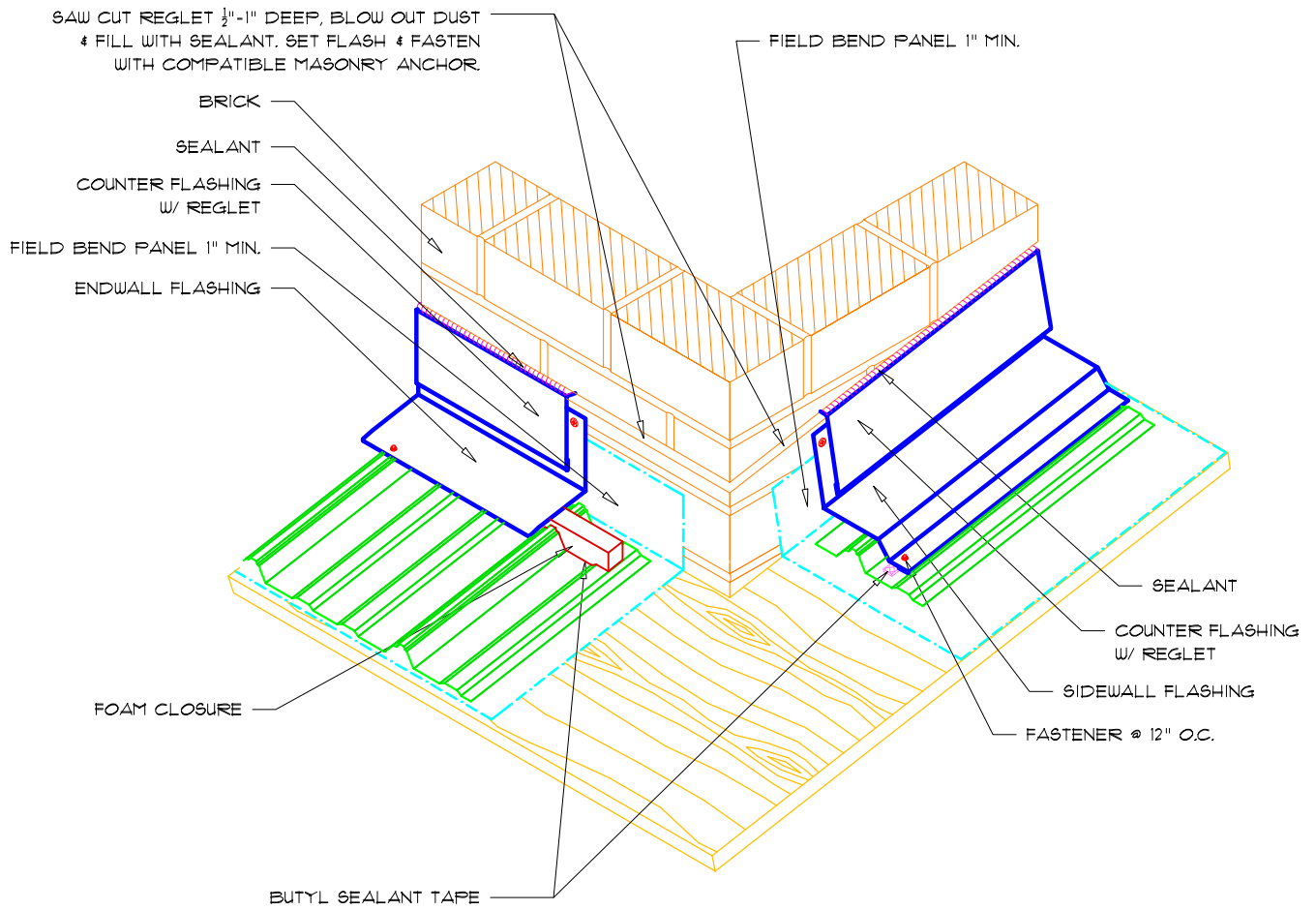

## CARE AND CLEANING

### **CARE AND CLEANING INSTRUCTIONS - COATED METAL**

#### **BACKGROUND**

As the owner of coated metal building, roof or structure, you will want to keep your investment functional and attractive for many years into the future. This document will detail the cleaning and care of your painted metal panels or structure. Most panels are either Hot Dipped Galvanized (HDG) or Galvalume, that are painted with a topcoat and backer to insure a fully protected product.

In a coil coating process, the coated steel is first thoroughly cleaned and rinsed so that a uniform surface is provided for a pretreatment phase. The pretreatment is a very thin layer that chemically bonds to the surface of the metal and provides a bonding surface for the subsequent primer and topcoat paint. The primer layer contains corrosion inhibitors and allows for the flexibility of the painted total painted system. The final coat is the top coat which provides colored pigments, gloss and UV radiation protection from the sun. During each application step the paint is control applied to insure film thickness and integrity, then baked to the desired physical properties.

The attractive appearance of your metal building or roof is the result of engineered products manufactured under controlled conditions to insure a quality product. To maintain the attractive appearance of your investment, periodic cleaning will be required. Care must be taken when cleaning the surface of the painted material, so as not to damage the film integrity of the paint. It is the purpose of these instructions to provide guidance for cleaning your painted metal.

#### **CLEANING COMMON PROBLEMS**

All painted metal will chalk and retain dirt to some degree, and mildew will build up in certain environments. These make the painted surface look dull and old over time. Removal of the dirt and surface chalk restores much of the paints brightness, and original color.

The selection of cleaning method will depend on the type of contaminant and to be removed. Common types of contaminants associated with painted metal buildings include;

- 1) Airborne dirt, which can collect on building surfaces along with greasy, organic residues, that cannot be removed by rainwater.
- 2) Chalk, which is natural degradation of paint systems. Over a period of several years a thin white chalky film is produced on the surface of the paint film, which makes the color appear to fade and reduces the gloss of the original paint.
- 3) Mildew, or biological growth, commonly appears on surfaces that are exposed to damp or wet environments, shield from direct sunlight, such as under eaves, north facing walls or sheltered areas.
- 4) Rust Stains, may be caused by steel debris left on the building following erection, unprotected cut edges, or unprotected fasteners. These sources of rust stain should be eliminated prior to cleaning.

# TUFF-RIB

## CARE AND CLEANING

### TYPES OF CLEANERS

A variety of cleaners remove dirt, mildew and chalk:

- ¼ cup phosphate free laundry detergent per gallon of water
- 1 ounce liquid dishwashing detergent per gallon of water
- ¼ cup household bleach per gallon of water
- ¼ cup household ammonia per gallon of water

It is important to rinse cleaners thoroughly from the surface. Detergents, ammoniated cleaners and bleach leave corrosive residues if not properly rinsed. Detergents and dishwashing soap can attract dirt if not thoroughly rinsed. When cleaning compounds are left on a building, not only will they attract dirt more readily, but will tend to corrode the building faster.

Powder and liquid detergents are excellent general cleaners, requiring low concentrations to achieve an acceptable cleanliness. The specific brand is not critical, as most will work fine, but **DO NOT USE** a phosphate detergent.

Some mildews will not come off, even with mild detergents, and will require a stronger cleaning agent. Household bleach, when mixed properly should clean most all mildew stains.

Ammonia is especially good for removing greasy dirt and stains, when solvents are inappropriate. Always dilute and mix ammonia in a well-ventilated area outdoors. Solvents are the most effective agent in cleaning greasy stains, when detergents and ammonia do not achieve an acceptable result. However, there are 3 serious limitations to using solvents for cleaning painted surfaces.

- 1) Solvents are flammable. Always use them in well ventilated areas. Keep away from any open flames, sparks, motors or other source of ignition. Do not use solvents for large cleaning operations.
- 2) Solvents can remove paint. Always test the paint to determine if the solvent will damage the coating.

The following presents some guidance on the subject:

- a. Polyesters and Silicon Modified Polyesters (SMP) are less solvent sensitive than Fluoropolymer, Kynar and Plastisol topcoats.
  - b. Alcohols are least aggressive solvents.
  - c. Petroleum solvents, such as Kerosene, Naptha, Mineral Spirits, turpentine, Toluol and chlorinated solvents are moderately aggressive.
  - d. Ketones, Esters and paint removers are the most aggressive, and when using them, you should expect to dull or damage the surface of the painted material.
- 3) Most solvents are toxic and great care should be taken in the use and disposal of them.

*Read the manufacturers information on any cleaning solvent to insure proper use.*

# TUFF-RIB

## CARE AND CLEANING

### DIRT RETENTION

Two types of dirt accumulate on buildings; dry soil and greasy or organic residues. The dry dirt, by itself, washes off with rainwater or high pressure water spray. Greasy residues do not wash off in rain and tend to hold dirt and chalk tightly to the surface. These residues originate from automobile exhaust, fireplaces, ventilation fan oil, pesticides, and various common sources. This is the kind of dirt that requires cleaners to remove. Detergents, ammoniated cleaners and even solvents maybe required to achieve an acceptably clean surface.

Lighter colors tend to show more dirt than darker colors. Polyester and SMP's tend to retain dirt more than Fluropon Kynars.

### CHALK

Chalk is the white byproduct of ultra-violet degradation of the paint system. It makes colors look lighter, reduces natural gloss of the paint system, and deposits on lower building surfaces and materials. Chalk builds up of a period of years, as rainwater only partially removes it.

The rate of chalk build up depends heavily on the type of pigment color and resin in the topcoat. In general, plastisols chalk more than polyesters, which chalk more than SMP's, which chalk more than Fluropons. Chalking on dark colors is more noticeable than chalking on lighter colors.

Chalking increases with greater sun exposure. Parts of the building that are southern facing, roofing and areas not shaded from sun may experience greater chalking. Generally high pressure water spray is all that is needed to remove chalk and restore the buildings original appearance.

### MILDEW

Mildew build up, or more generally biological growth, on buildings requires a long wet exposure with proper nutrients to form. There is sufficient supply of organisms in dust to initiate growth anywhere. North facing walls, under eaves and sheltered corners are areas that can have layers of build-up. A visible growth of mildew holds moisture easily. Mildew is also has corrosion issues since the by-products of bacteriological growth are corrosive.

Remove mildew by wiping or by using power spray. Then wash the area with an antiseptic cleaner such as bleach described above. Rinse the area thoroughly. Eliminating the cause of the mildew prevents its return.

Bleaches can be unsafe to mix with other cleaners. Use pre-mixed laundry detergents with bleach if extra cleaning is needed. Bleach is toxic and corrosive. Avoid eye and skin contact. Keep it off nearby shrubs and plants.

# TUFF-RIB

## CARE AND CLEANING

### RUST REMOVAL

Cleaning red rust and red rust stains from buildings includes the need to eliminate the source of rust before cleaning. In many circumstances, removing the rust is the final step in the repair of a rust source. The following are examples of rust removal:

- 1) **Rust Rundown** – Rust can stain panels when rust runs down from a higher, rusting panel. After elimination of the upper panel rusting, cleaning permanently removes rust on the lower panel.
- 2) **Rust from Steel Debris** – After removal of steel debris left on the building, cleaning permanently removes the stain
- 3) **Edge Rust** – The bottom edges of panels that have prolonged exposure to wet or damp environments will have red rust. After correcting the edge design, to allow easy drying, cleaning and permanently removes the rust. If it is not possible to correct the design, repainting of the edges following rust removal may be required.
- 4) **Painting Rusted Area** – Completely remove the rust prior to repainting the area or the repainting will not adhere.

Any cleaner should be thoroughly rinsed off after application. Rinse with tap water very thoroughly. Acid cleaners attack metallic coatings if left in contact for a sufficiently long time.



**POSTEE L**  
**BUILDINGS**

**877-386-2068**

**JDMETALS.NET**